

TRANSLYFT HYGIENIC DESIGN

THE CLEANEST SOLUTION



TECHNICAL SPECIFICATIONS

NOTE: EVERYTHING CAN BE CUSTOMIZED FOR YOUR NEEDS

- > AVAILABLE IN AISI 304 AND 316
- > LIFT CAPACITY: FROM 1000 - 2000 KG
- > TRAVEL: 820 - 830 MM.
- > CLOSED HEIGHT: 180 - 230 MM.
- > LENGTH: 1400 MM.
- > WIDTH: 1040 MM.
- > POWER SUPPLY: 3x400 V/50 Hz+PE *
(PLEASE INQUIRE FOR OTHER POWER SUPPLY NEEDS)
- > CE MARKED
- > CLEANING MODE FOR BETTER CLEANING OF LIFT (SEE BELOW)
- > WITH OR WITHOUT CLEANING SLOTS
- > HIGHER FOOD SAFETY AFTER CLEANING
- FEWER BACTERIA LEFT ON TABLE (DOCUMENTED EFFECT)
- > AVAILABLE WITH SEMI STAINLESS OR COMPLETELY STAINLESS CYLINDER (VERSION 2 AND 3)
- > RUNS 10 LIFTS PER HOUR 8 HOURS A DAY (FULL TRAVEL)
- PLEASE INQUIRE FOR INTENSIVE USE
- > 2 SAFETY LOCKS FOR MAINTENANCE
- > STAINLESS STEEL SAFETY TRIP BAR WITH OPEN CORNERS THAT ALLOWS FOR BETTER CLEANING

Significantly better hygiene level
up to 50% savings in terms of
cleaning time and cost



The TRANSLYFT Hygienic Design is our premium stainless steel lifting solution that reassures a better hygiene chain and more efficient work place. The solution can withstand intensive cleaning and is therefore particularly suitable for environments where hygiene is essential.

The cleaning mode makes it possible to raise the platform resulting in more efficient cleaning and a significantly better hygiene level. Consequently you save both time, water and detergent during the cleaning process.

The TRANSLYFT Hygienic Design can be applied to all standard models or we can customize a solution for you. More information at www.translyft.com



The cleaning mode facility makes you save both time, water and detergent.



The platform can be equipped with slots to further ease the cleaning process.



The lifting table can be equipped to fit your needs. This one is made for smoke trolleys.

Type	Capacity LBS	Travel in.	Closed height in.	Total raised height in.	Length in.	Width in.	Lift time sec	Motor kW	Weight LBS
HL 1000 B	2200	33"	8"	40"	52"	32"	18	0.75	386
HL 1000 F	2200	33"	8"	40"	52"	40"	18	0.75	397
HL 2000	4400	33"	10"	42"	52"	32"	27	0.75	530
HL 2000 F	4400	33"	10"	42"	52"	40"	27	0.75	530
HLD 1000	2200	63"	15"	78"	52"	32"	30	0.75	684
HLD 1000 F	2200	63"	15"	78"	52"	40"	30	0.75	750
HLD 2000	4400	63"	16"	79"	52"	36"	32	0.75	827
HLD 2000 F	4400	63"	16"	79"	52"	40"	32	2.2	904
HLH 2000	4400	33"	8"	40"	103"	32"	36	2.2	717
HUB 1000	2200	29"	4"	32"	58"	43"	12	0.75	519
HUB 2000	4400	28"	5"	32"	60"	48"	16	1.1	717

Separate power unit is standard on TRANSLYFT Hygienic Design models.

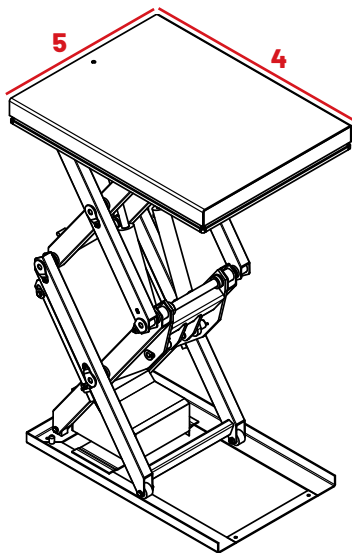

- Capacity Highest load capability (when loaded correctly)
- Travel (1) Travel from closed height to top position
- Closed height (2) Height at lowest position
- Total raised height (3) Height at top position
- Length (4) Platform length
- Width (5) Platform width
- Lift time Time in sec. to top position
- Motor Size of motor
- Weight Weight of table

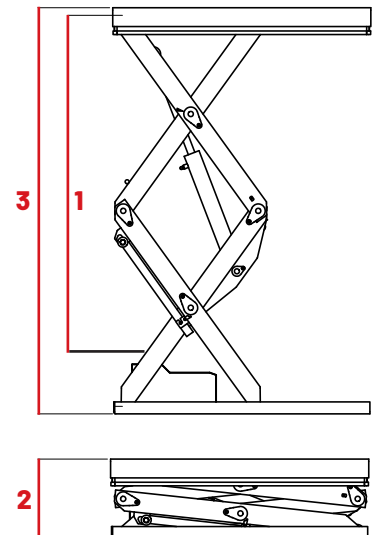

We know that every lift is unique and that all workspaces are different.
 Contact us at +45 9886 4900 to find the perfect Hygienic Design lifting table for you.